

PORTABLE STUDIO LIGHTING SYSTEM

Operating Instructions

Introduction

This portable Lighting System is an All-in-One Lighting Kit for Digital (and Film) Photography of small objects. It consists of 2 mini fluorescent light banks, several background papers of different colors and a host on mounting accessories designed for setting up a shooting platform, utilizing the carrying case as the chassis.

The following figure shows the various components of the kit and how the system will look like when it is set up.

1. Parts of the Portable Studio Lighting System 224

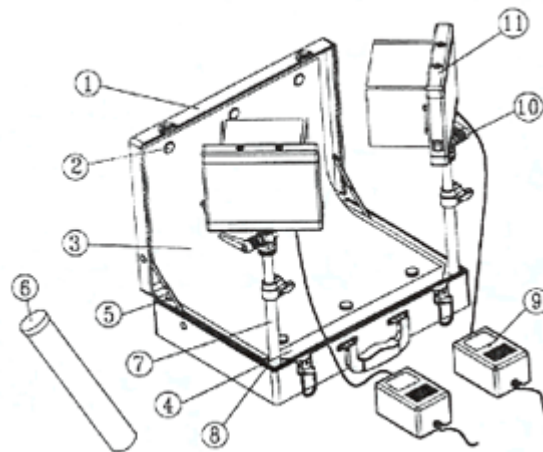

1 Carrying Case	6 Background Paper Holder
2 Magnetic Holder (6)	7 Mounting Pole (2)
3 Background Paper (5)	8 Mounting Hole for Mounting Pole (2)
4 Diffuser Plate	9 AC/DC Adaptor (2)
5 Support Pin (4)	10 Pan Tilt Bracket (2)
	11 Mini Fluorescent Light Bank with Barn Door (2)

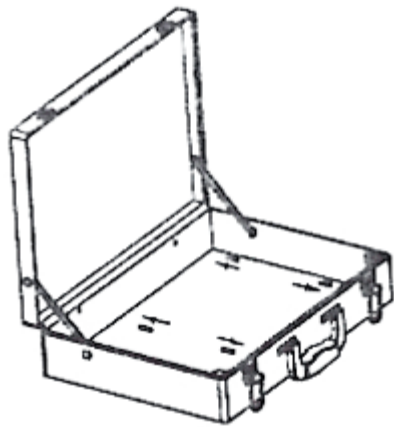

Fig. 1

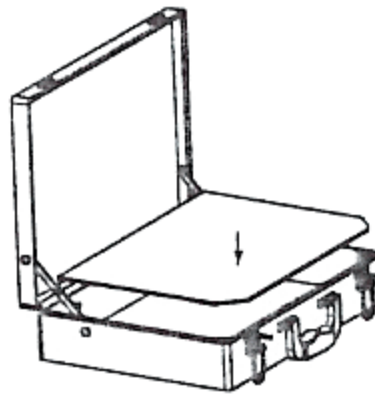

Fig. 2

How to Set Up

A. Setting up the Shooting Platform

- a) Remove everything from the carrying case and leave the top half of the case in the flipped open position.
- b) There are 4 holes marked with ↑ in the lower half of the case, 2 in the front and 2 in the rear. Insert the Support Pins into these holes (Fig. 1). They will become the supports for the diffuser plate.
- c) Lay the Diffuser Plate on the Support Pins with the metal strip facing up in the front (Fig. 2).

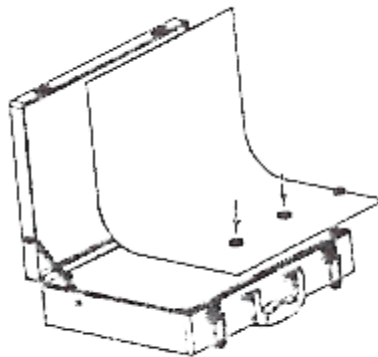

Fig. 3

- d) Choose the desired Background Paper from the Background Holder. Use 3 Magnetic Holders to put one end of the Background Paper in position against the metal strip on the Diffuser Plate (Fig. 3).
- e) Stretch the Background Paper over the Diffuser Plate and extend it to the top half of the Carrying Case. Again, use the remaining 3 Magnetic Holders to put the other end of the paper against the metal Strip along the edge of the top half of the Carrying Case. This completes Set up of the Shooting Table.

B. Setting up the Lights

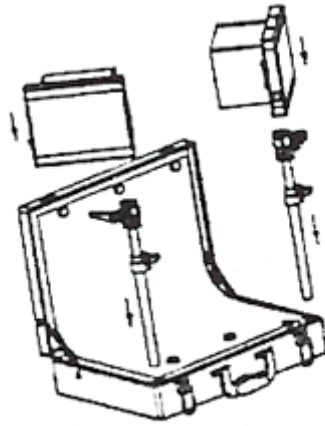

Fig. 4

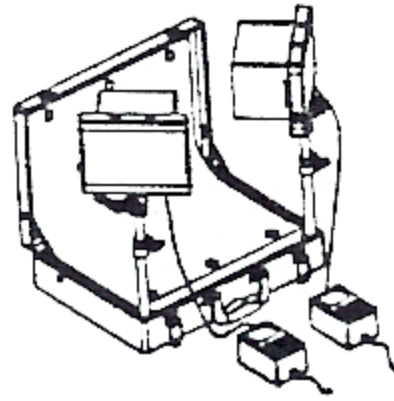

Fig. 5

- Connect the Pan Tilt Bracket to the Mounting Pole and install the Mini Fluorescent Light Bank to the Pan Tilt Bracket.
- Insert the Mounting Pole into the Mounting Hole in the lower half of the Carrying Case. (Fig. 4).
- Plug the AC/DC Adaptor Plug into the sockets on the Mini Fluorescent Light Banks (Fig. 5).
- Turn on the Light Banks for a while until the brightness becomes steady. The shooting platform is now ready for use.

C. Alternative Set up

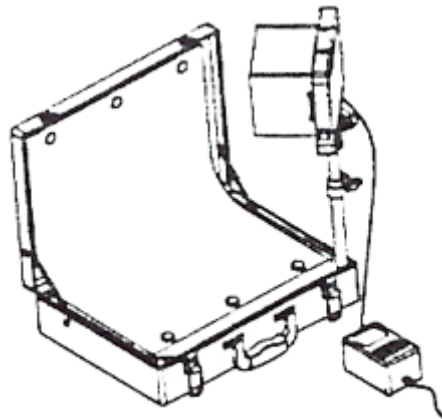

Fig. 6

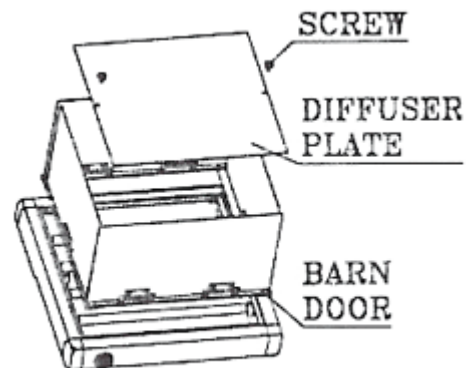

Fig. 7

Apart from direct illumination with 2 Light Banks from the front and in elevated positions, there is an alternative set up for the lighting – put 1 Light Bank underneath the Diffuser Plate and leave the other one in the front (Fig. 6). The Light Bank below the Diffuser Plate will eliminate shadows effectively from the Background.

Before the Light Bank is put underneath the Diffuser Plate, the barn door must be removed first through the following procedures (Fig. 7).

- Loosen the screws on the top of the diffusion plate of the Light Bank.
- Remove the diffusion plate and the barn door.

To set up, follow the same procedures as in steps A and B above except that the Light Bank, with the diffusion plate and barn door removed, should be put into the Carrying Case before the Diffuser Plate is installed.

Specifications

Model	PSLS 5000/224
Max Height of Shooting Area	290 mm
Max. Width of Shooting Area	410 mm
Color Temperature	Approx. 5000 Kelvin
Power Source	AC/DC Adaptor with DC 24V 1A Output
Includes	1 x Carrying Case 2 x Mini Fluorescent Light Bank (24W) 2 x Mounting Pole and Pan Tilt Bracket 2 x AC/DC Adaptor 1 x Background Paper Holder 5 x Background Paper 1 x Diffuser Plate with Metal Strip 4 x Support Pin 6 x Magnetic Holder
Dimensions of Case (External)	450 x 355 x 120 mm
Weight	7.75 kg (approx. 17 lbs)